

X-Ray RU953



ARIOTEK® Luggage X-Ray Detection System



Key Features

- High-End Processor Technology
- Luggage Counter
- Previous Visible Image Recall
- Image Evaluation Function (VARY-MAT, O2, OS, HI/LO)
- B/W – Color Image Presentation
- Full Reverse Mode
- Time/Date Displaying & Marking
- Dual-Direction Scanning, 45s Ready to Work
- Multi Language Interface (Persian-English-Arabic)

Rayan Roshd Afzar .Co (Ltd) is the first manufacturer of X-Ray inspection systems licensed by Atomic Energy Organization of Iran (AEOI) and the European standard (CE) with **ARIOTEK** brand for using at airports, country borders, customs and important public, administrative and Security.

An X-Ray detection system comprised of Ergonomic user interface, Powerful functions, Ease of operation, High operational efficiency, Organic and Inorganic material discrimination technology for Explosive and Narcotics automatic detection, providing unsurpassed image quality and insuring reliable image analysis.

General Specifications

Tunnel Size	511(W) × 316(H) (mm)
Max Object Size	500(W) × 300(H) (mm)
Conveyor Belt Speed	0.2 m/s
Conveyor Height	220 mm
Conveyor Load	120 kg (evenly distributed)
Dimensions	1190(L) × 720(W) × 838(H) (mm)
Weight	approx. 228Kg

Technical

X-Ray Detectors	16 bit deep, Dual Energy
Wire Resolution	38 AWG (0, 101 mm Cu)
Steel Penetration	Up to 10 mm
Contrast Sensitivity	65536 Gray Level

X-Ray Generator

X-Ray Generator	1 unit
Anode/Tube Voltage Output	100 kV
Tube Current	1.5 mA
Cooling	Air cooling
Duty Cycle	100%, No Warm up Procedure Required
Beam Direction	64° downward generating direction

Video

Display Type	Single 22Full HD Color Monitor
Display Resolution	1280×1080, 24 Bit/Pixel Color

Installation data

Mechanical Construction	Steel construction on roller castors
Sound Pressure Level	<65 db
Operating /Storage Temperature	5°C to +40°C / -10°C to +60°C
Relative Humidity	5% - 85% (non-condensing)
Protection Class System	IP20

Electrical

Power Requirement	220-230 VAC, 50 Hz, approx. 0.8kVA
-------------------	------------------------------------

Health & Safety

Radiation Standards	IEC-IAEA-ICRP-WHO
Film Safety	ISO 1600 film guaranteed
X-Ray Radiation Dose/Scan	<2 μSv
Radiation Emission Leakage	< 0.5 μSv/h at a distance of 5 cm from external surface of the cabinet X-Ray

Standard Features

- 4 Color Imaging
- Baggage Counter
- Time/Date Display
- Color and Black/White Imaging
- Continues Zoom to64x
- Vertical Zoom Panning
- Drugs & Explosive Material Automatic Detection
- Density Alert
- Edge – Enhancement Imaging
- High Penetration Function
- Image Review
- Material Discrimination
- Organic /Inorganic Imaging
- Reverse Monochrome
- Image Automatic Storage , Image Recall
- Manual Bitmap Archive
- USB Storage,CD,DVDRW & Image Storage/TCP/IP
- Real – Time Self-Diagnostics
- Dual-Direction Scanning
- Operator Training System

Optional Features

- 24" Full HD LCD Monitor
- Adjustable Operator Console
- External UPS (1kVA, 2hrs)
- Entry/Exit Roller Table (Customized Dimensions)
- Local Language Support

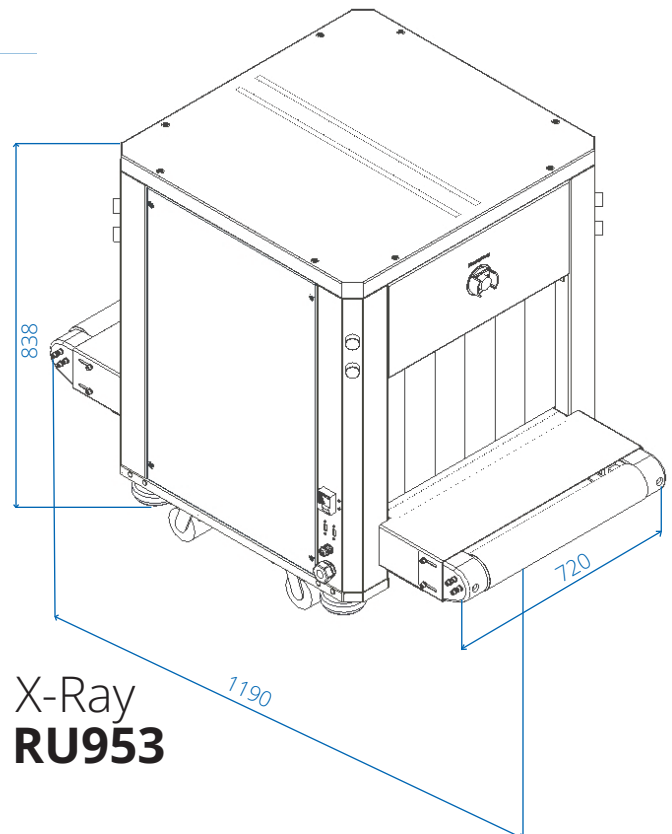

Office Address:

No 2, Yasaman Ave, Yas 3 St., Golha Blvd, Golestan (Raah Aahan) Residential District, Tehran, Iran,

Phone: +9821- 44716393

+9821-44717868

+9821- 44716451

+9821-44716458

Fax: +9821- 44716404

Website: www.ariotek.ir

Email: sale@rayanroshd.ir

ARIOTEK[®]

CSP

ISO 9001:2015

CE

AEOI

AEOI

Knowledge-Based Product